

## Microphone assembly instructions

The resistors are all metal film 1% types, color coded with 5 bands. Here is the color code chart for resistors. In case of doubt, use an ohm meter to check the value.

COLOR	1 <sup>ST</sup> BAND	2 <sup>ND</sup> BAND	3 <sup>RD</sup> BAND	MULTIPLIER	TOLERANCE
Black	0	0	0	1Ω	
Brown	1	1	1	10Ω	± 1% (F)
Red	2	2	2	100Ω	± 2% (G)
Orange	3	3	3	1KΩ	
Yellow	4	4	4	10KΩ	
Green	5	5	5	100KΩ	± 0.5% (D)
Blue	6	6	6	1MΩ	± 0.25% (C)
Violet	7	7	7	10MΩ	± 0.10% (B)
Grey	8	8	8		± 0.05%
White	9	9	9		
Gold				0.1Ω	± 5% (J)
Silver				0.01Ω	± 10% (K)

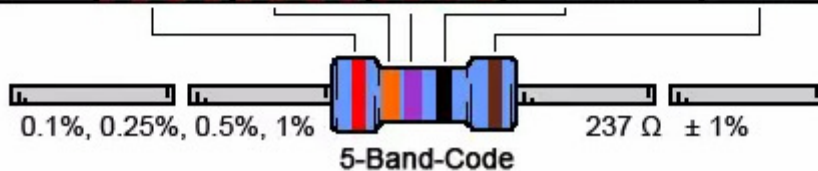

1. First we start to assemble the DC/DC converter. This circuit converts the voltage derived from the phantom power, to +60 Volts for the polarisation voltage of the capsule. We start with the two diodes 1N4148. The type number is in small print on the diodes. The black band on the diodes should match the screenprint on the PCB.

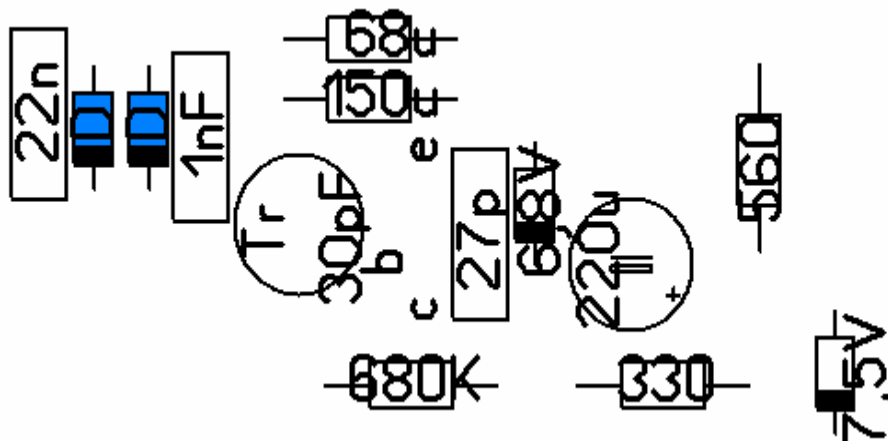

2. Next we mount the two zener diodes, marked 6V8 and 7V5, respectively 6.8 Volt (**blue**) and 7.5 Volt (**red**). Here it is also important to observe the correct orientation!

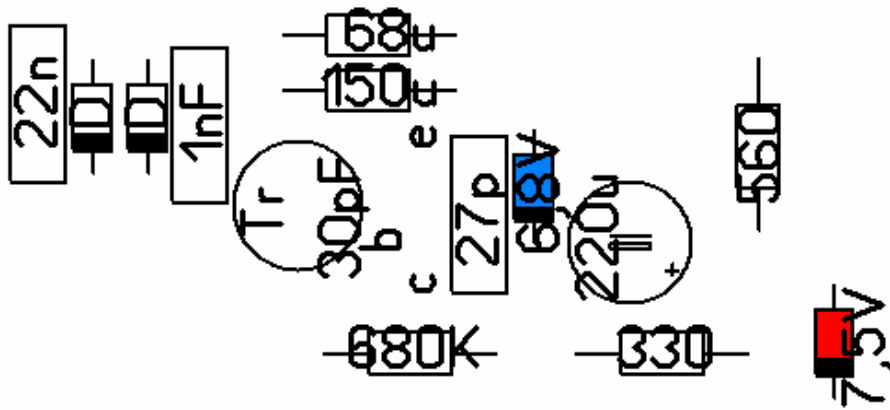

3. Next insert the inductors. The inductors have a similar color code as resistors. The 68 uH one is **blue-gray-black**, the 150 uH one is **brown-green-brown**. Orientation is not important, but make sure the right value is in the correct place and mount them very **close** together, preferably (almost) touching each other.

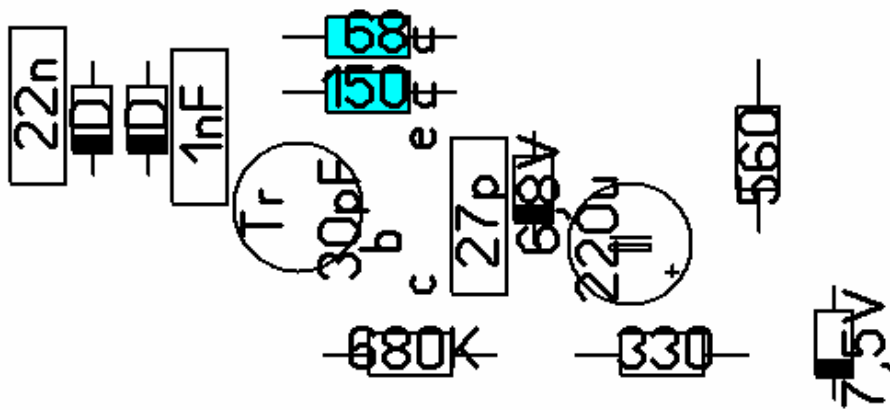

4. Now mount the next three resistors. 680K.ohm (**red**), 330 ohm (**blue**) and 560 ohm (**green**)

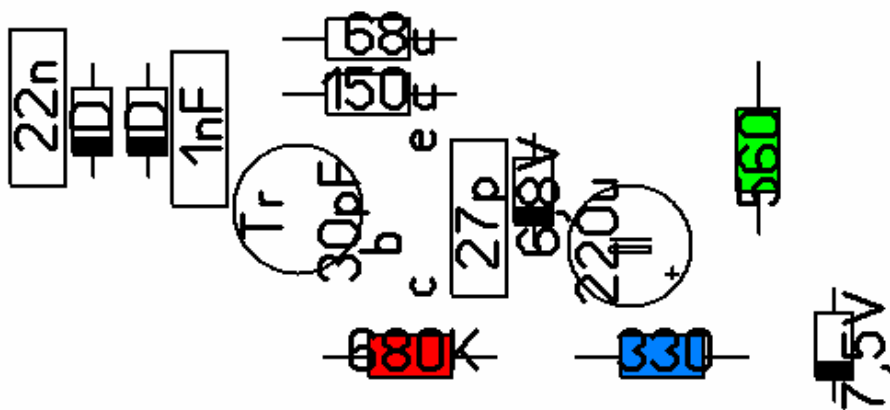

5. Place the 1nF capacitor (**red**) marked 1 nF or 1000 pF, and the 22nF capacitor (**blue**) marked 22 nF or 0.022.

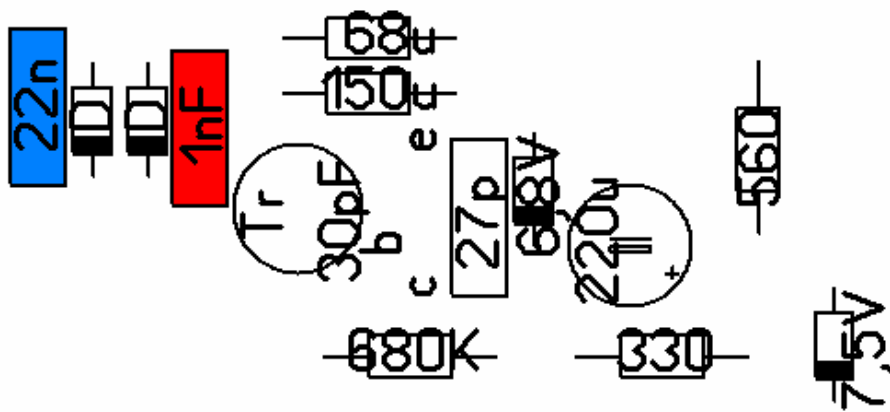

6. Insert the (green) 30 pF trimmer (**green**) and the 220 uF electrolytic capacitor (**blue**). Observe the polarity, the + side of the capacitor should be close to the 330 ohm resistor.

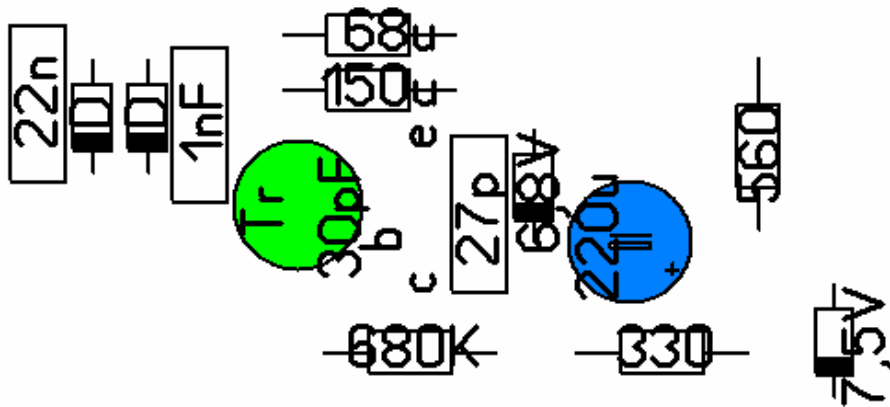

7. Place the BC547(b) transistor. The wires of the transistor are placed in a triangle, that matches the hole pattern of the printed circuit board. The flat side of the transistor should be close to the 27 pF capacitor.

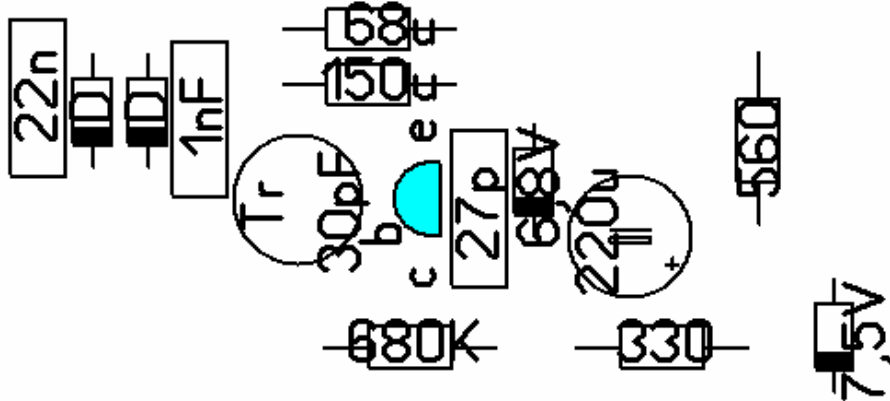

8. Last part in the DC/DC converter circuit is the 27 pF capacitor, marked 27.

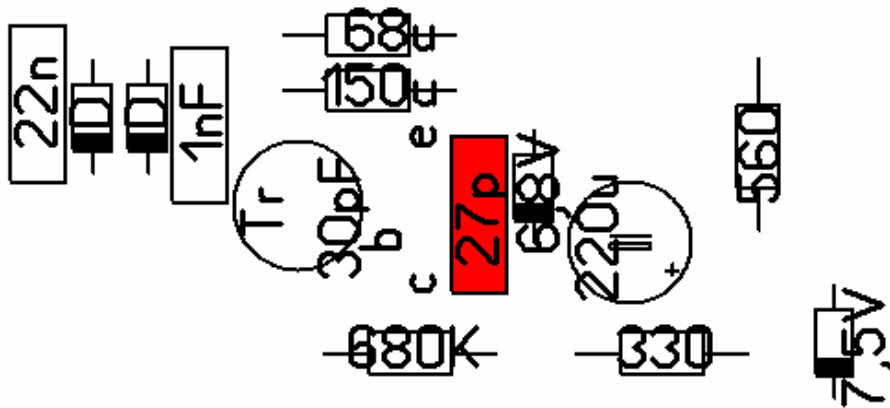

This completes the build of the DC/DC converter.

9. Before we continue with the rest of the circuit, we first **test** if the DC/DC converter works. To do this, we need a 9 Volts power source, this can be a (small) power supply, or a 9 Volts battery. To measure, we need a multimeter in the 100 Volts range. In order to check the DC/DC converter, we have to make a couple of temporary connections, as shown in the picture below:

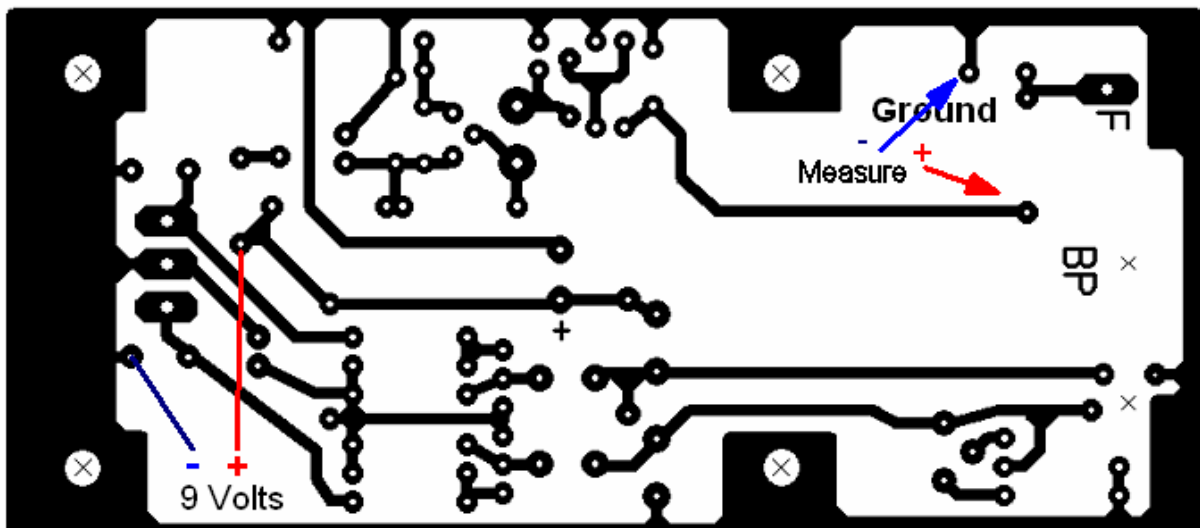

The two wires (red and blue) go to the 9 V power source or battery. You measure the voltage between Ground (the trace surrounding the PCB) and the point marked with a red arrow. You should get something like 60 V. If the voltage is low, try rotating the green trimmer. The voltage is not very critical, anything between 55 V and 60 V. is fine. If this test is successful with the correct voltage, we can continue.

10. Next mount the 470 uF capacitor and the 47 uF capacitor.

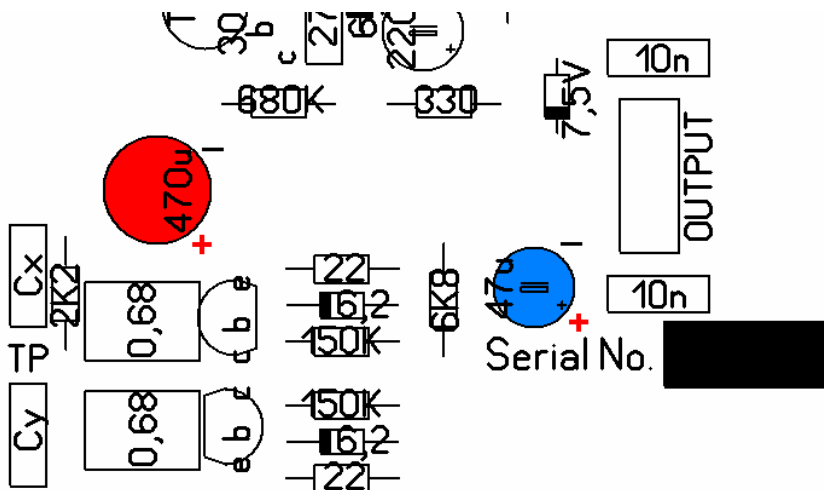

The + side of the 470 uF capacitor should be close to the 0,68 uF.

11. Place the two 22 ohm resistors (red) and the 10nF capacitors (blue).  
 10 nF = 0.01 uF.

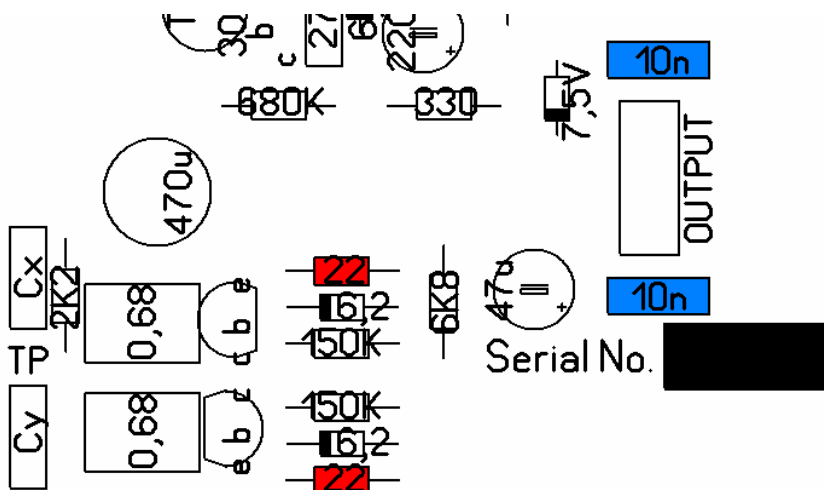

12. Next, insert the two 150 K.ohm resistors (**red**) and the 6.8 K.ohm (6K8) resistor (**blue**).

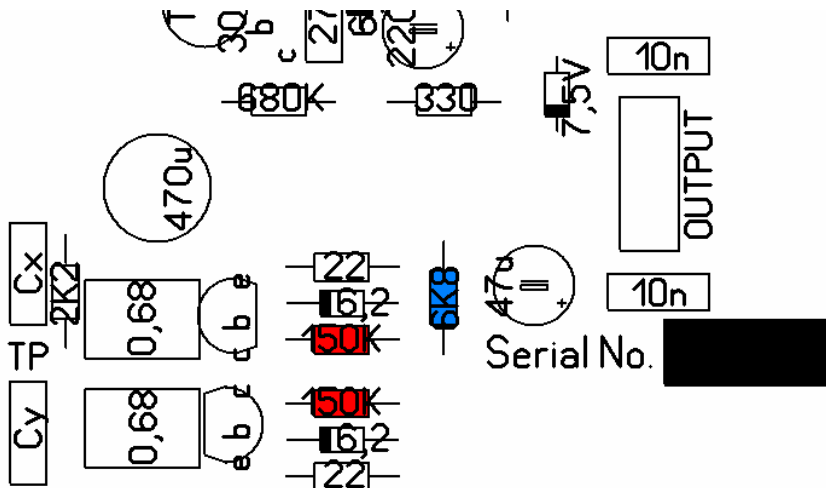

13. Now place the two BC557(b) transistors (**red**). This time the wires from the transistors are in a single row. Note that the flat side of the transistors is on the left for the bottom one, and to the right for the top one. Also place the two 6.2 V. (6V2) zener diodes (**blue**).

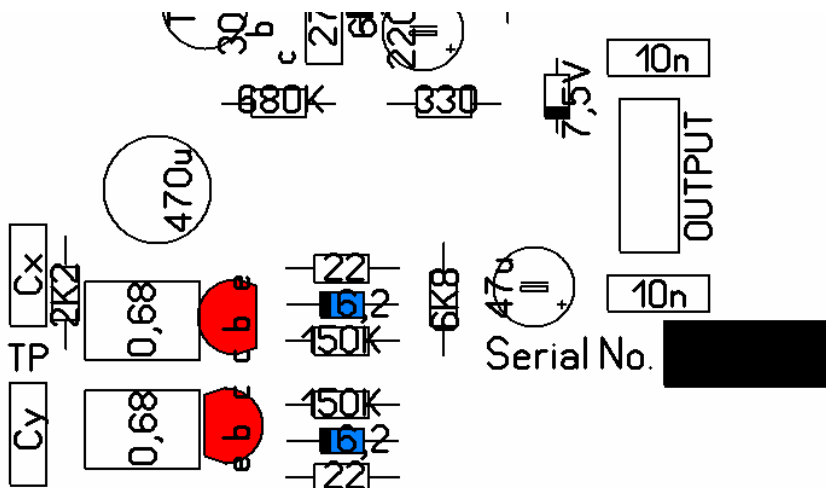

14. Now place the two 0.68 uF capacitors (**red**) and the two 2.2 K.ohm (2K2) resistors (**blue**)

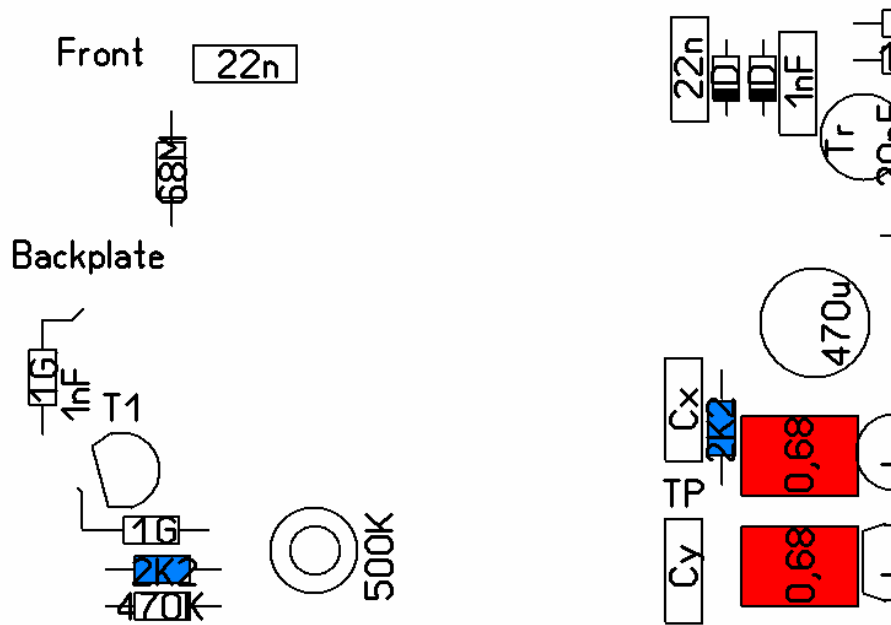

15. Next, insert the 470 K.ohm resistor (**red**) and the 68 M.ohm resistor (**green**)

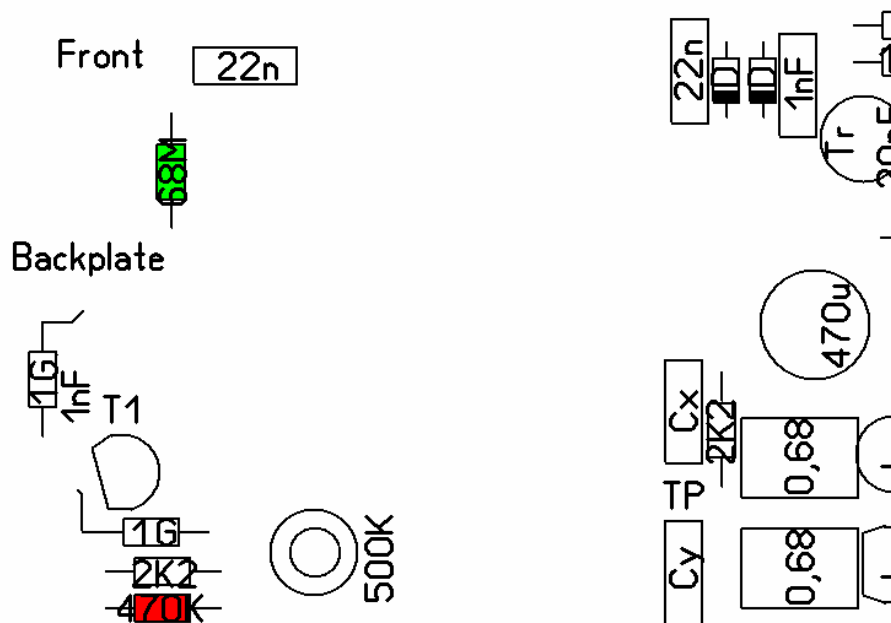

16. Place the 22 nF (.022uF) capacitor (**red**) and the 500 K.ohm trimpot. (**blue**).

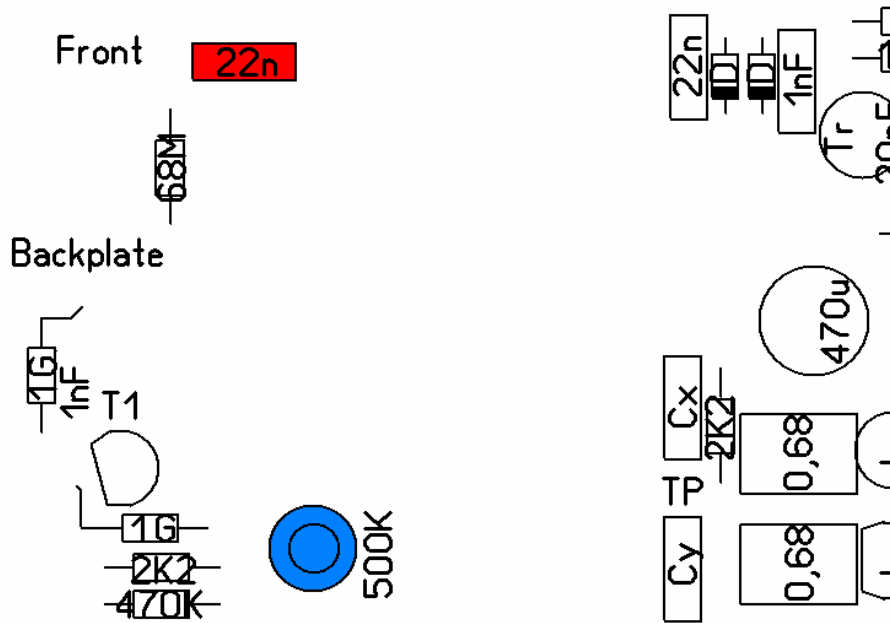

17. Now insert the two teflon insulator pins from the component side of the printed circuit board. They will serve as soldering points for the two 1 G.ohm resistors and the gate of the FET.

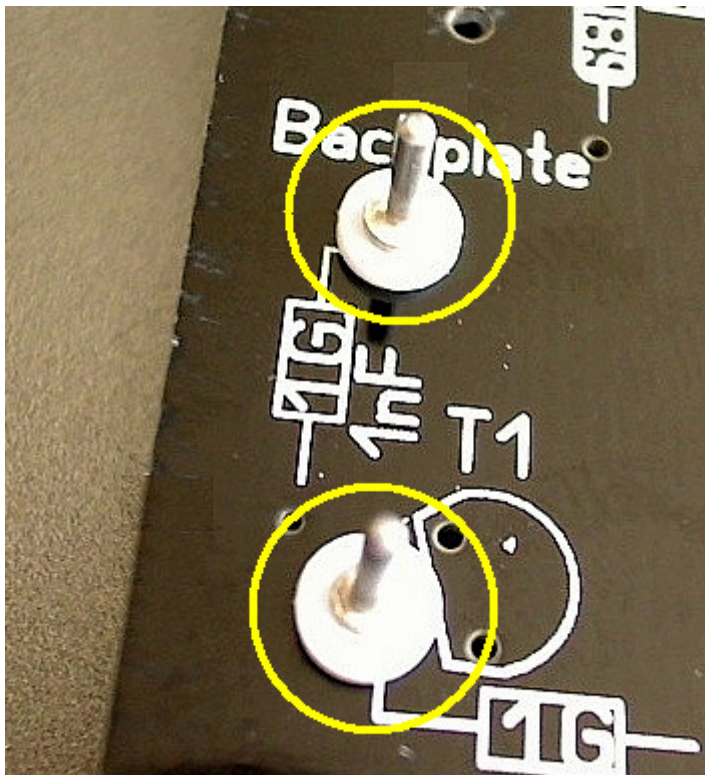

18. Prepare the (2SK170BL) FET, by bending the middle wire out, in the direction of the flat side with an angle of about 90 degrees. Insert the two outer wires of the FET as shown on the screenprint of the PCB. The wire in the middle, that we have just bent out, goes to the



teflon insulator pin. Solder the outer wires of the FET to the PCB, but **don't** solder the wire yet to the teflon insulator pin!

19. Prepare the two 1 G.ohm resistors, by bending a single wire on an angle of 90 degrees. Those wires go through the holes in the PCB. Solder the single wires of the 1 G.ohm resistors in such a way, that the resistors don't touch the PCB, but are 1 mm. (or a little more) 'floating' above the surface of the printed circuit board. The other ends of the 1 G.ohm resistors are soldered to the teflon insulator pins. (One wire of a 1 G.ohm resistor is soldered together with the wire of the FET transistor.)

20. Solder the 1 nF (1000pF) styroflex capacitor between the two teflon pins, on the other side of the printed circuit board, so: at the side where the traces are. Don't overheat this capacitor!

22. You may have noticed that there is one capacitor of 10 nF left. No, you didn't forget this one! This capacitor is only needed if you are using a K67 style microphone capsule. If you are using a K47 or CK12 capsule, you don't need this extra capacitor. In this case, just keep it as a souvenir... If you are using a K67 style capsule, mount the extra 10 nF capacitor in the holes marked 'Cx'.

23. Connect the PCB to the XLR connector in the microphone body. You can use the solder pins to make connection easier. The connector should be wired like this:

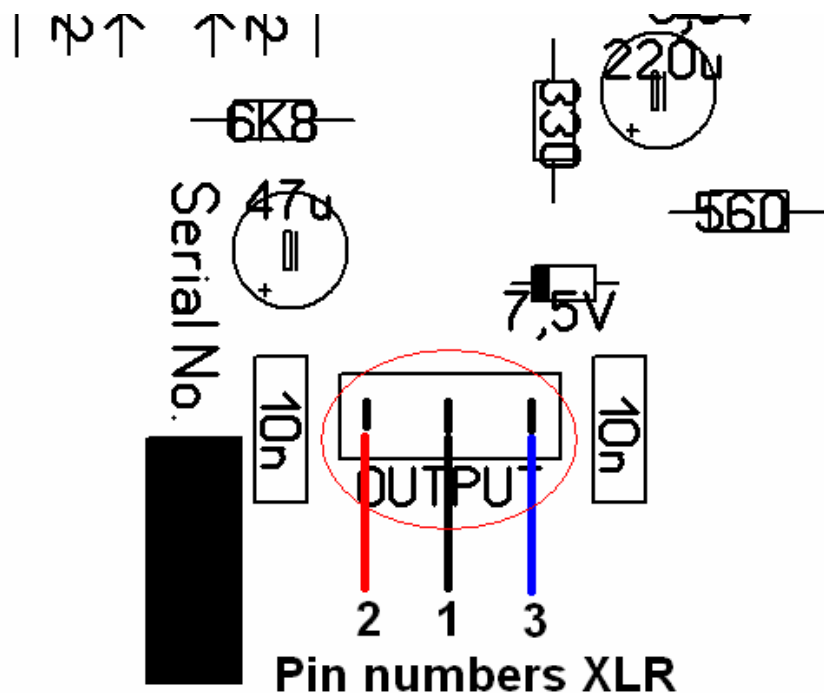

24. Connect the microphone circuit to a mixer or microphone amplifier with 48 V. Phantom power switched on, and check the voltage on the Test Point (TP). You measure between the connection going to pin 1 of the XLR, ('ground') and the TestPoint the arrow points at, so in

fact one side of the 2.2 K.ohm resistor:

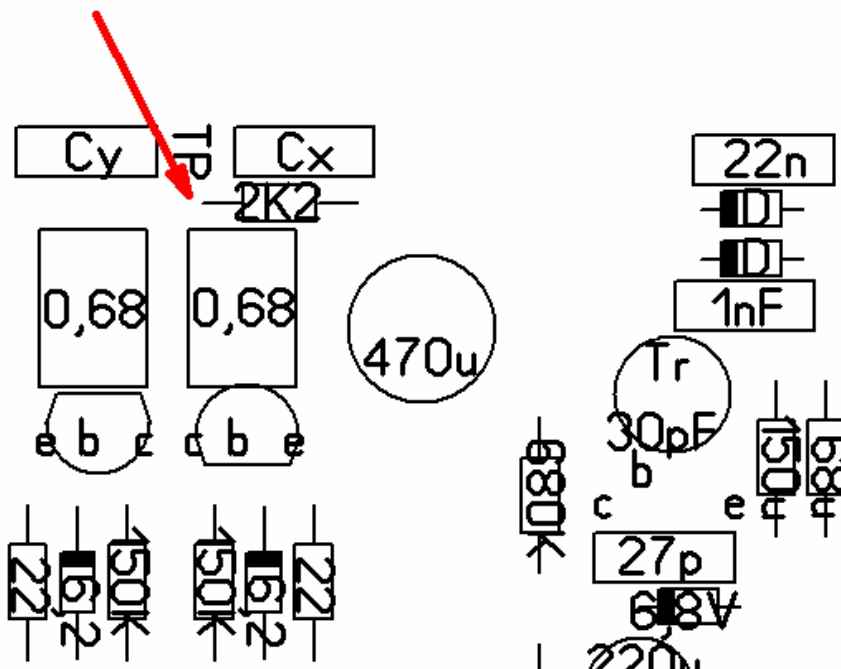

The voltage at this point should be 5.25 Volt, but it probably will be higher or lower. **Slowly** rotate the 500 K.ohm trimpot (**NOT** the 30 pF trimmer!) and observe the voltage. Aim for 5.25 Volt. You will notice that the voltage *changes slowly*. If you are close to 5.25 Volt, let the circuit alone for a couple of minutes and check again. Maybe you will feel the need to readjust the voltage. When the voltage stays stable at 5.25 Volts, don't touch the trimpot anymore! You may even secure the position of the trimpot with a small drop of nailpolish, to keep it where it is.

25 Finally, connect the microphone capsule. You can use a solder pin for the 'Front' connection. The front diaphragm is connected to 'Front' and the backplate of the capsule is connected to the tefon pin marked 'Backplate'. Make sure the capsule wires are not longer than needed, because loose capsule wires can later produce unwanted sounds, especially if the microphone is used with loud sources.

If everything went well, you now have a working microphone, that will give you excellent quality for many years!